

# HITCH ADAPTER SIZE CHART

To find a hitch adapter that will ensure proper lift functionality. **Reference the chart below.**

**HV:** Distance from the ground to the bottom opening of hitch receiver

**D1:** Distance from the center of the pin hole to the furthest point toward the rear of the vehicle.

**D2:** Distance from the center of the pin hole to the furthest point towards the front of the vehicle going through the hitch receiver. In some cases the tire is the furthest point.

**⚠ WARNING**

Only use Harmar-approved hitch adapters with Harmar lifts. Hitch expanders and extenders are strictly prohibited—using them or any other after-market accessory may result in damage to the vehicle, lift and/or personal injury to the user.

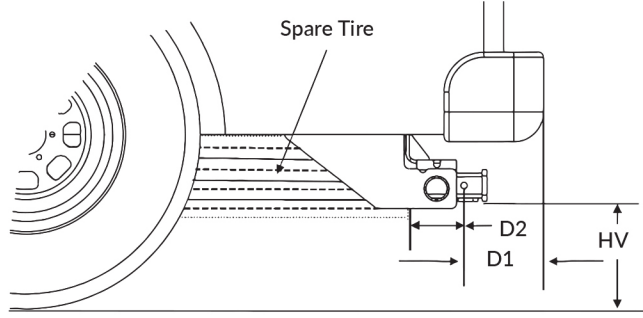

STANDARD APPLICATION						APPLICATION WITH SWING-AWAY		
Class	Part#	Description	HV	D1	D2	HV	D1	D2
Class 1	AL121	STANDARD	6"–18"	≤ 7.5"	≥ 1"	6"–16"	0"–7.5"	≥ 1"
Class 2	AL126	STANDARD	6"–18"	≤ 7.5"	≥ 2"	6"–16"	0"–7.5"	≥ 2"
	AL1262	STANDARD: 2" DROP	18"–20"	≤ 7.5"	≥ 2"	16"–18"	0"–7.5"	≥ 2"
	*AL1265	STANDARD 4.25" DROP	20"–22"	≤ 7.5"	≥ 2"	18"–20"	0"–7.5"	≥ 2"
	AL127	EXTRA LONG	6"–18"	7.5"–10.5"	≥ 2"	6"–16"	7.5"–10.5"	≥ 2"
	AL1272	EXTRA LONG: 2" DROP	18"–20"	7.5"–10.5"	≥ 2"	16"–18"	7.5"–10.5"	≥ 2"
	*AL1275	EXTRA LONG: 5" DROP	20"–23"	7.5"–10.5"	≥ 2"	18"–21"	7.5"–10.5"	≥ 2"
	AL128	SHORT	6"–18"	≤ 5"	≥ 1.5"	6"–16"	0"–5"	≥ 1.5"
	*AL1285	SHORT: 4.25" DROP	20"–22"	≤ 5"	≥ 1.5"	18"–20"	0"–5"	≥ 1.5"
	AL111	STANDARD: (FOR AL001 ONLY)	6"–18"	≤ 5"	≥ 2"	N/A	N/A	N/A
Class 3	AL123	STANDARD	6"–18"	≤ 8"	≥ 5"	6"–16"	0"–8"	≥ 5"
	AL123HD	HEAVY DUTY: STANDARD	6"–18"	≤ 8"	≥ 5"	6"–16"	0"–8"	≥ 5"
	AL1232HD	HEAVY DUTY: 2" DROP	18"–20"	≤ 8"	≥ 5"	16"–18"	0"–8"	≥ 5"
	*AL1235HD	HEAVY DUTY: 5" DROP	20"–23"	≤ 8"	≥ 5"	18"–21"	0"–8"	≥ 5"
	*AL1235U	UNIVERSAL: STD - 5" DROP	6"–23"	≤ 8"	≥ 5"	6"–21"	0"–8"	≥ 5"
	*AL1236	STANDARD: 6" DROP	20"–24"	≤ 8"	≥ 5"	18"–22"	0"–8"	≥ 5"
Class 3	*AL1236HD	HEAVY DUTY: 6" DROP	20"–24"	≤ 8"	≥ 5"	18"–22"	0"–8"	≥ 5"
	*AL1238	STANDARD: 8" DROP	24"–26"	≤ 8"	≥ 5"	22"–24"	0"–8"	≥ 5"
	*AL1238HD	HEAVY DUTY: 8" DROP	24"–26"	≤ 8"	≥ 5"	22"–24"	0"–8"	≥ 5"
	AL124	SHORT: STANDARD	6"–18"	≤ 4"	≥ 3.5"	6"–16"	0"–4"	≥ 3.5"
	AL124HD	HEAVY DUTY SHORT: STANDARD	6"–18"	≤ 4"	≥ 3.5"	6"–16"	0"–4"	≥ 3.5"
	AL1242	SHORT: 2" DROP	18"–20"	≤ 4"	≥ 3.5"	16"–18"	0"–4"	≥ 3.5"
	*AL1242HD	HEAVY DUTY SHORT: 2" DROP	18"–20"	≤ 4"	≥ 3.5"	16"–18"	0"–4"	≥ 3.5"
	*AL1245	SHORT: 5" DROP	20"–23"	≤ 4"	≥ 3.5"	18"–21"	≤ 4"	≥ 3.5"
	*AL1246	SHORT: 6" DROP	20"–24"	≤ 4"	≥ 3.5"	18"–22"	0"–4"	≥ 3.5"
	*AL1246HD	HEAVY DUTY SHORT: 6" DROP	20"–24"	≤ 4"	≥ 3.5"	18"–22"	0"–4"	≥ 3.5"
	AL125HD	HEAVY DUTY EXTRA LONG: STANDARD	6"–18"	7.5"–13.5"	≥ 5"	6"–16"	7.5"–13.5"	≥ 5"
	AL1252	EXTRA LONG: 2" DROP	18"–20"	7.5"–13.5"	≥ 5"	16"–18"	7.5"–13.5"	≥ 5"
	AL1252HD	HEAVY DUTY EXTRA LONG: 2" DROP	18"–20"	7.5"–13.5"	≥ 5"	16"–18"	7.5"–13.5"	≥ 5"
	*AL1255HD	HEAVY DUTY EXTRA LONG: 5" DROP	20"–23"	7.5"–13.5"	≥ 5"	18"–21"	7.5"–13.5"	≥ 5"
	*AL1256	EXTRA LONG: 6" DROP	20"–24"	7.5"–13.5"	≥ 5"	18"–22"	7.5"–13.5"	≥ 5"
	*AL1256HD	HEAVY DUTY EXTRA LONG: 6" DROP	20"–24"	7.5"–13.5"	≥ 5"	18"–22"	7.5"–13.5"	≥ 5"
	*AL1258HD	HEAVY DUTY EXTRA LONG: 8" DROP	24"–26"	7.5"–13.5"	≥ 5"	22"–24"	7.5"–13.5"	≥ 5"
	H300102	RV HITCH: STANDARD	6"–19"	≤ 6"	≥ 4"	6"–17"	0"–4.5"	≥ 4"
*AL12332	RV HITCH: 12" DROP	21"–30"	≤ 6"	≥ 4"	19"–28"	0"–4"	≥ 4"	
Class 5	AL123V	STANDARD	6"–18"	≤ 8"	≥ 5"	6"–16"	0"–8"	≥ 5"
	AL1232V	STANDARD: 2" DROP	18"–20"	≤ 8"	≥ 5"	16"–18"	0"–8"	≥ 5"
	*AL1235V	STANDARD: 5" DROP	20"–23"	≤ 8"	≥ 5"	18"–21"	0"–8"	≥ 5"
	*AL1236V	STANDARD: 6" DROP	20"–24"	≤ 8"	≥ 5"	18"–22"	0"–8"	≥ 5"

\* Not applicable with AL105L

Round measures up if greater than 1/2" and down if less than 1/2".